



Answers That Matter.

Wireless Recording Of The Electrophysiology Of Cognition In Psychiatric Disease Models

Presenters: Matthieu Albasser & John Huxter
Lilly Research Centre, Eli Lilly & Co. Ltd., Windlesham UK



The hippocampus is:

- part of the temporal lobe

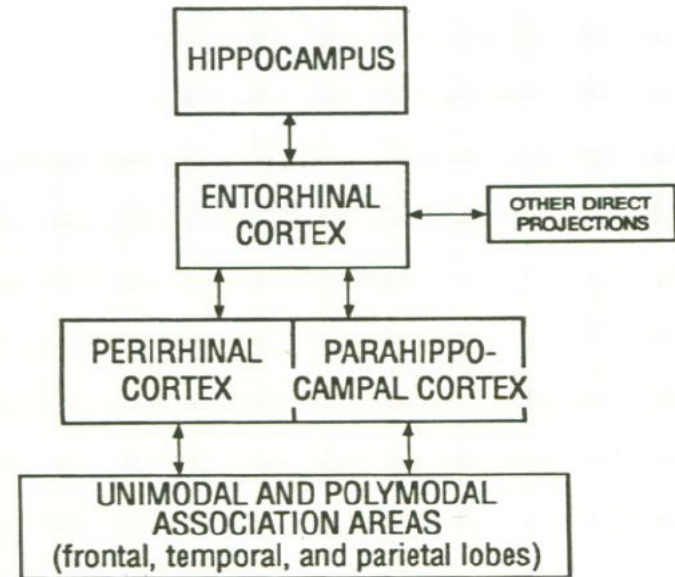
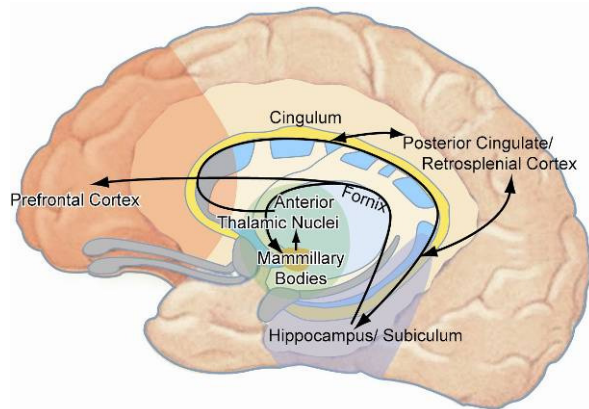

- vital for declarative/episodic memory , working memory and spatial memory

- Hippocampal memory deficits are a key feature of a number of **neurodegenerative** and **psychiatric disorders**

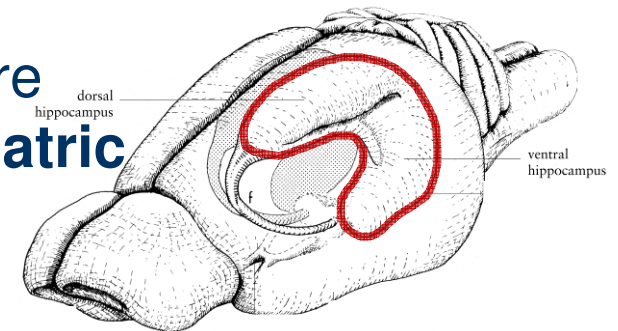

The standard T-Maze rewarded alternation task is highly sensitive to **hippocampal** manipulations (e.g. lesion studies)

- Movie unavailable online



Animals must be handled between the two phases and between trials

Lilly

Automated T-Maze: Rewarded alternation task

Sample phase
'Forced choice'

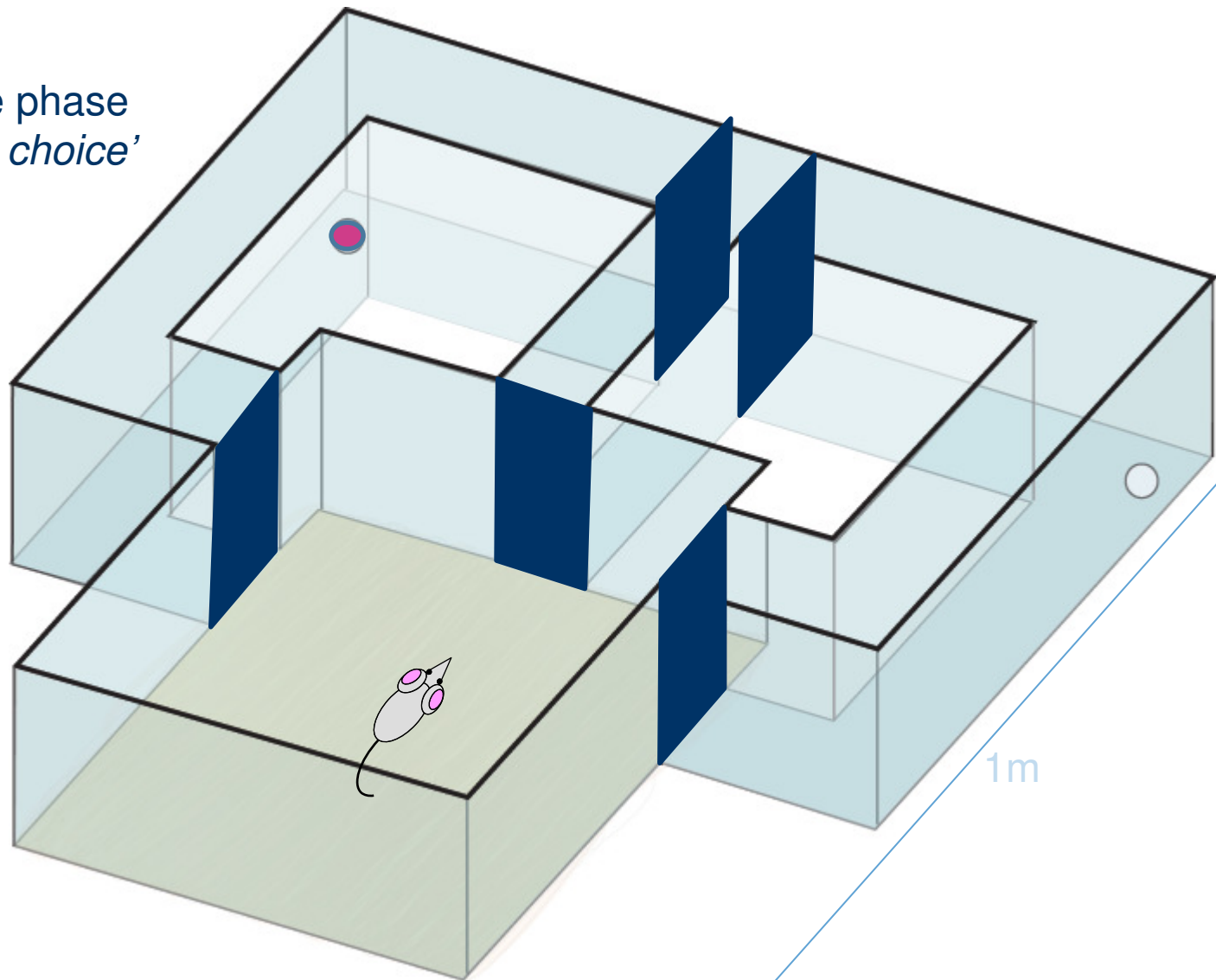

Automated T-Maze: Rewarded alternation task

Test phase
'Free choice'

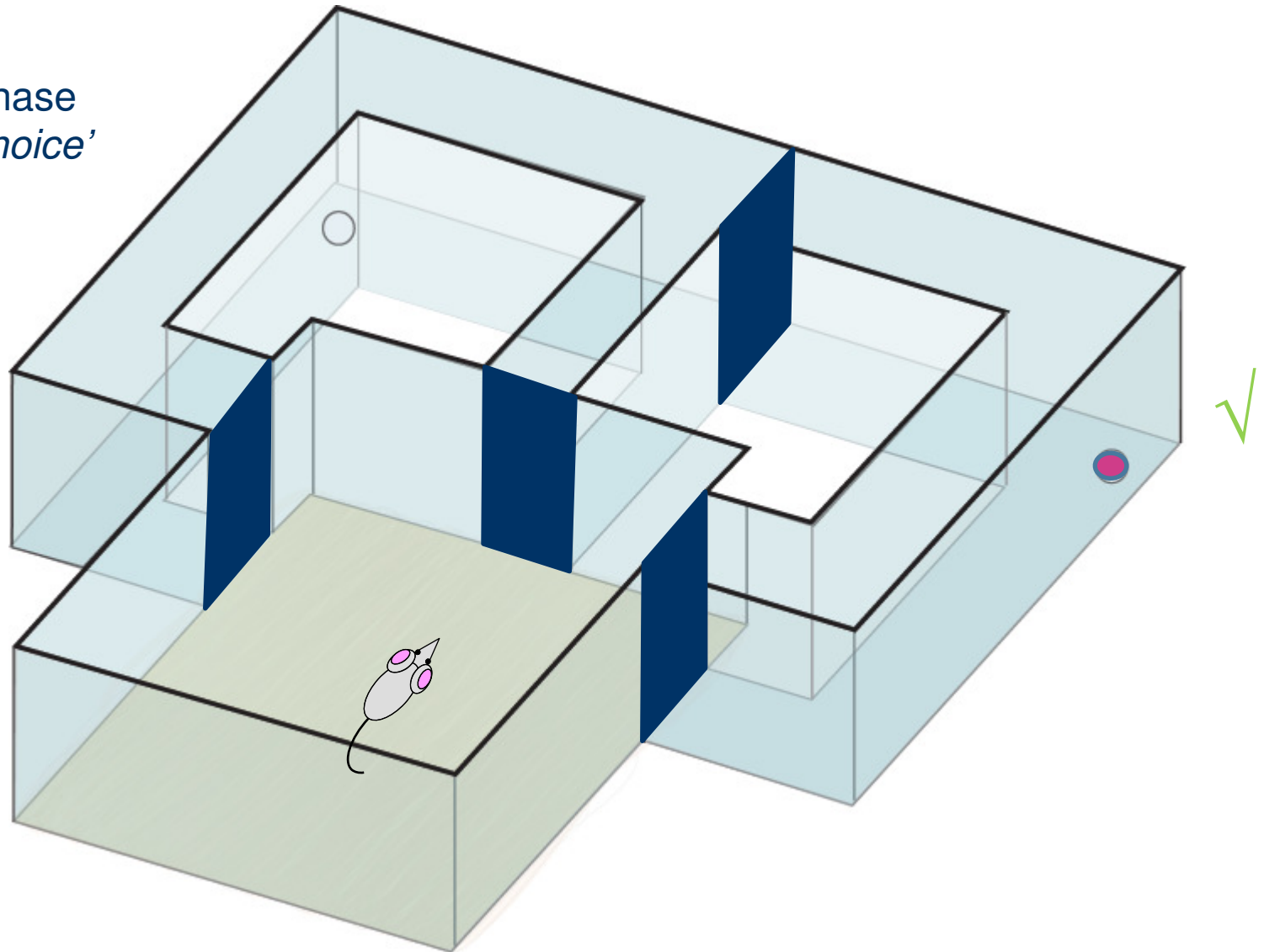

Validation of the Automated T-Maze: Hippocampal lesions

Standard T-Maze

60 trials

Automated T-Maze

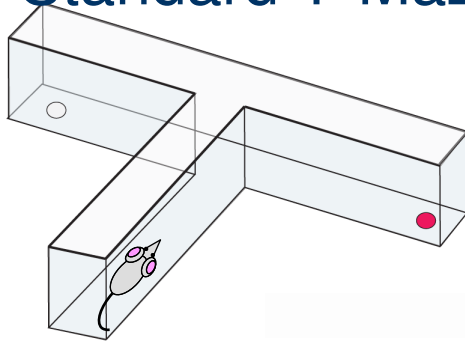

**Both tasks are
Hippocampus-dependent**

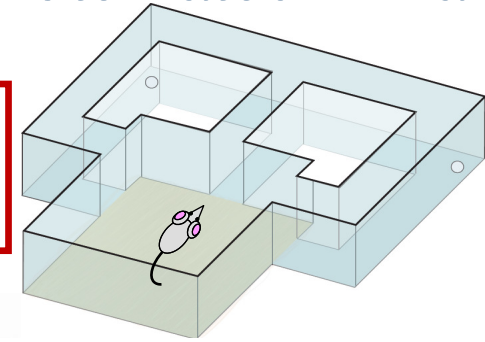

2 weeks

2 days

Standard T- Maze versus Automated T-Maze

Standard T-Maze

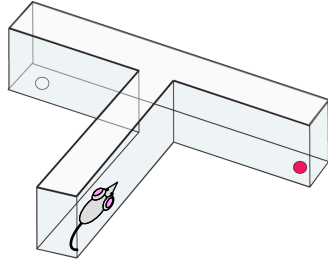

- Manual
- Behaviour output:
correct/incorrect response
- Intense handling:
 - stress
 - performance
- Low throughput: 2 weeks

X 3Rs benefits

Automated T-Maze

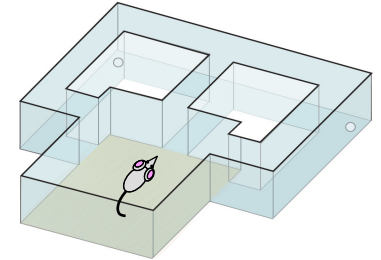

- Automated and computerised
- Behaviour output:
correct/incorrect response,
latency (+ lights and tones)
- No handling:
 - stress
 - performance
- High throughput: 2-3 days

➤ **Overall, the Automated T-Maze provides greater statistical power from fewer animals**

✓ 3Rs benefits

Electrophysiological recordings reveal the neuronal activity supporting performance on these tasks, while the animal is performing them

- The firing rate of single cells in the hippocampus can encode spatial information (place cells)
- While in the prefrontal cortex “delay firing working memory cells” can encode short term memory.

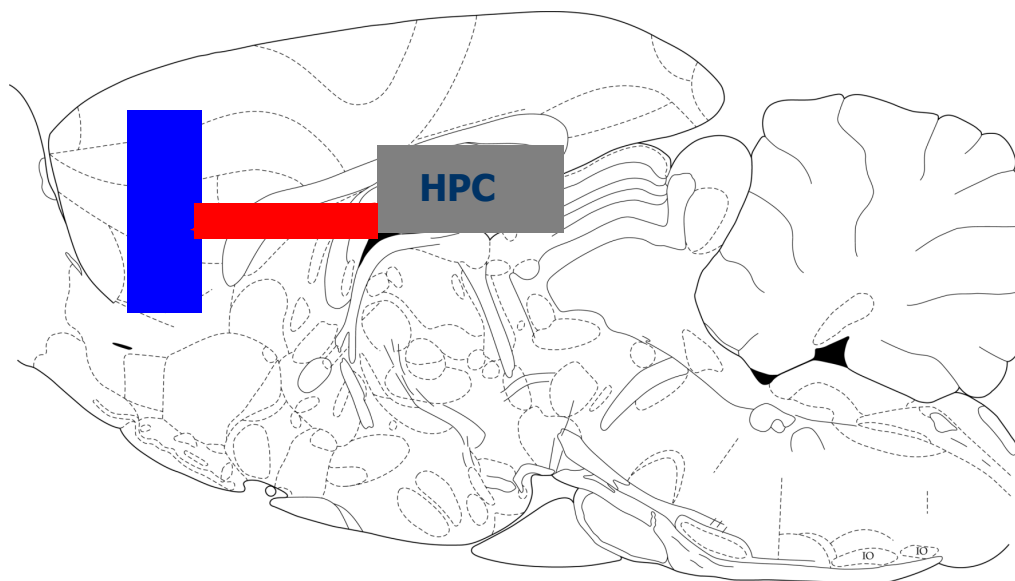
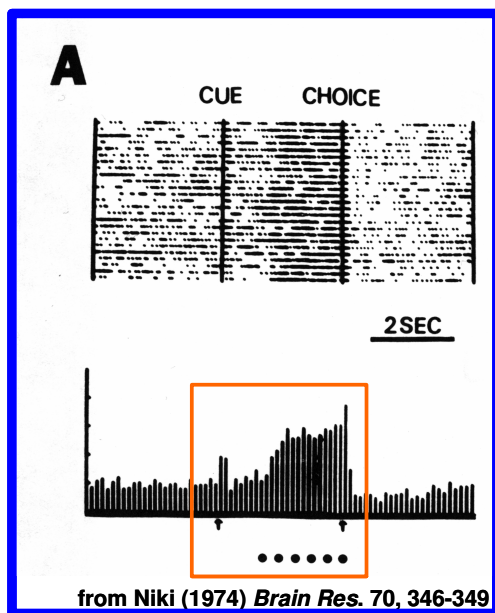
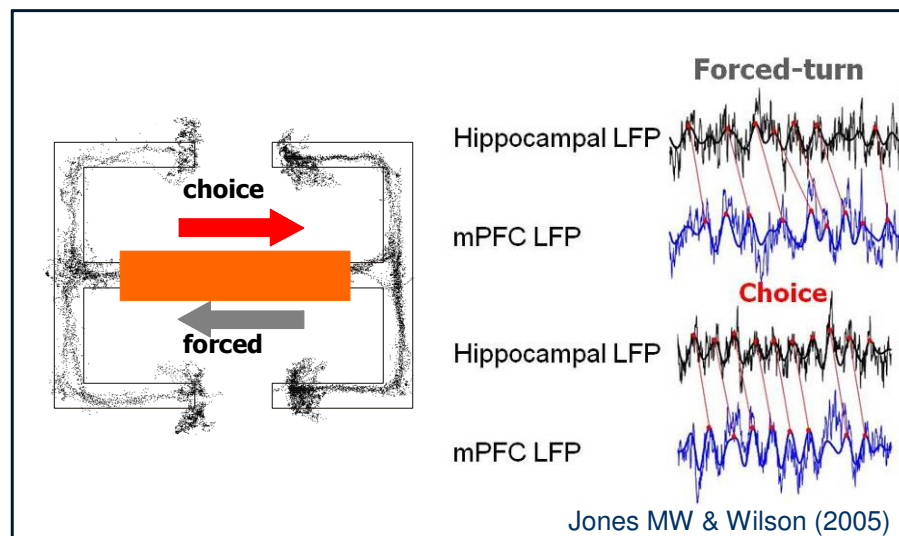

Hippocampal-prefrontal interactions

- Hippocampal-prefrontal recordings have shown that neuronal networks in these areas synchronise at the choice point in spatial working memory tasks (single unit and EEG)

Neuron
Article



Coherent Theta Oscillations and Reorganization of Spike Timing in the Hippocampal-Prefrontal Network upon Learning

Karim Benchenane,^{1,7,*} Adrien Peyrache,¹ Mehdi Khamassi,^{1,2} Patrick L. Tierney,^{3,4} Yves Gioanni,³ Francesco P. Battaglia,^{1,5,6,*} and Sidney I. Wiener^{1,6}

A

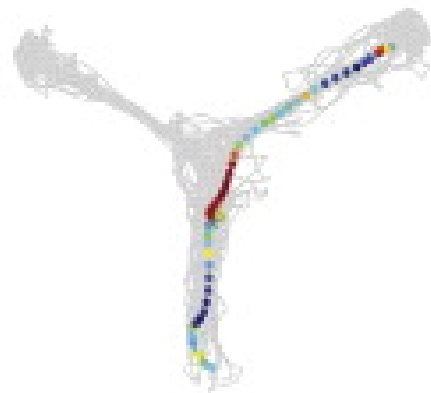

B

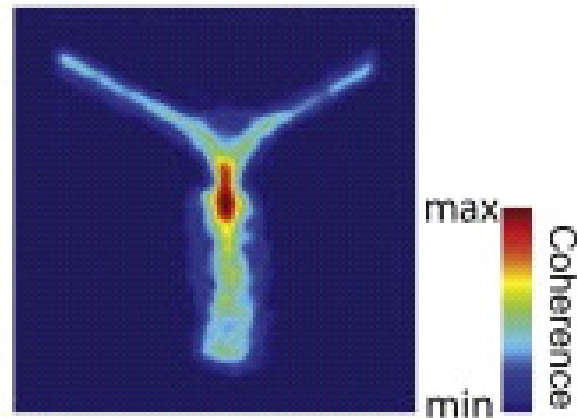

Prefrontal-hippocampal synchrony is impaired in both a genetic mouse model of schizophrenia and in patients during high working memory load

Vol 464 | 1 April 2010 | doi:10.1038/nature08855

nature

LETTERS

Impaired hippocampal-prefrontal synchrony in a genetic mouse model of schizophrenia

Torfi Sigurdsson¹, Kimberly L. Stark^{1,2}, Maria Karayiorgou^{1,4}, Joseph A. Gogos^{2,3} & Joshua A. Gordon^{1,4}

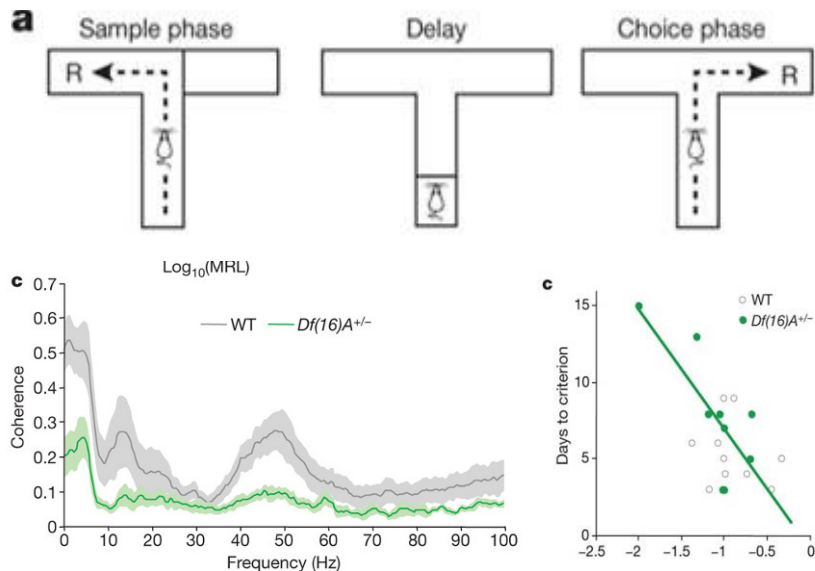

- Prefrontal-hippocampal coherence was reduced and could be used to **predict t-maze learning deficit.**



Neural Mechanisms of a Genome-Wide Supported Psychosis Variant

Christine Eslinger,^{1*} Henrik Walter,^{2,3*} Peter Kirsch,^{1*} Susanne Erk,³ Knut Schnell,^{2,3} Claudia Arnold,³ Leila Haddad,¹ Daniela Mier,¹ Carola Opitz von Boberfeld,³ Kyeon Raab,¹ Stephanie H. Witt,⁴ Marcella Rietschel,⁴ Sven Cichon,⁵ Andreas Meyer-Lindenberg^{1†}

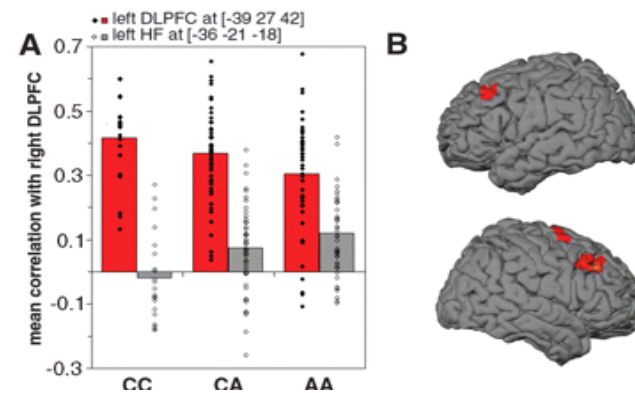

- Disrupted prefrontal synchrony in schizophrenic patients

Can we modulate these network impairments to provide new therapies?

Lilly

Electrophysiology methodology

- Chronic implants contain moveable arrays of
 - twisted 4-wire electrodes (tetrodes), or
 - multi-site silicone probes
- Position is adjusted after recovery from surgery
- Allows
 - precise (μM) positioning -> large cell yields
 - reduced pre-recording tissue damage in the area of interest
 - hunting for cell types

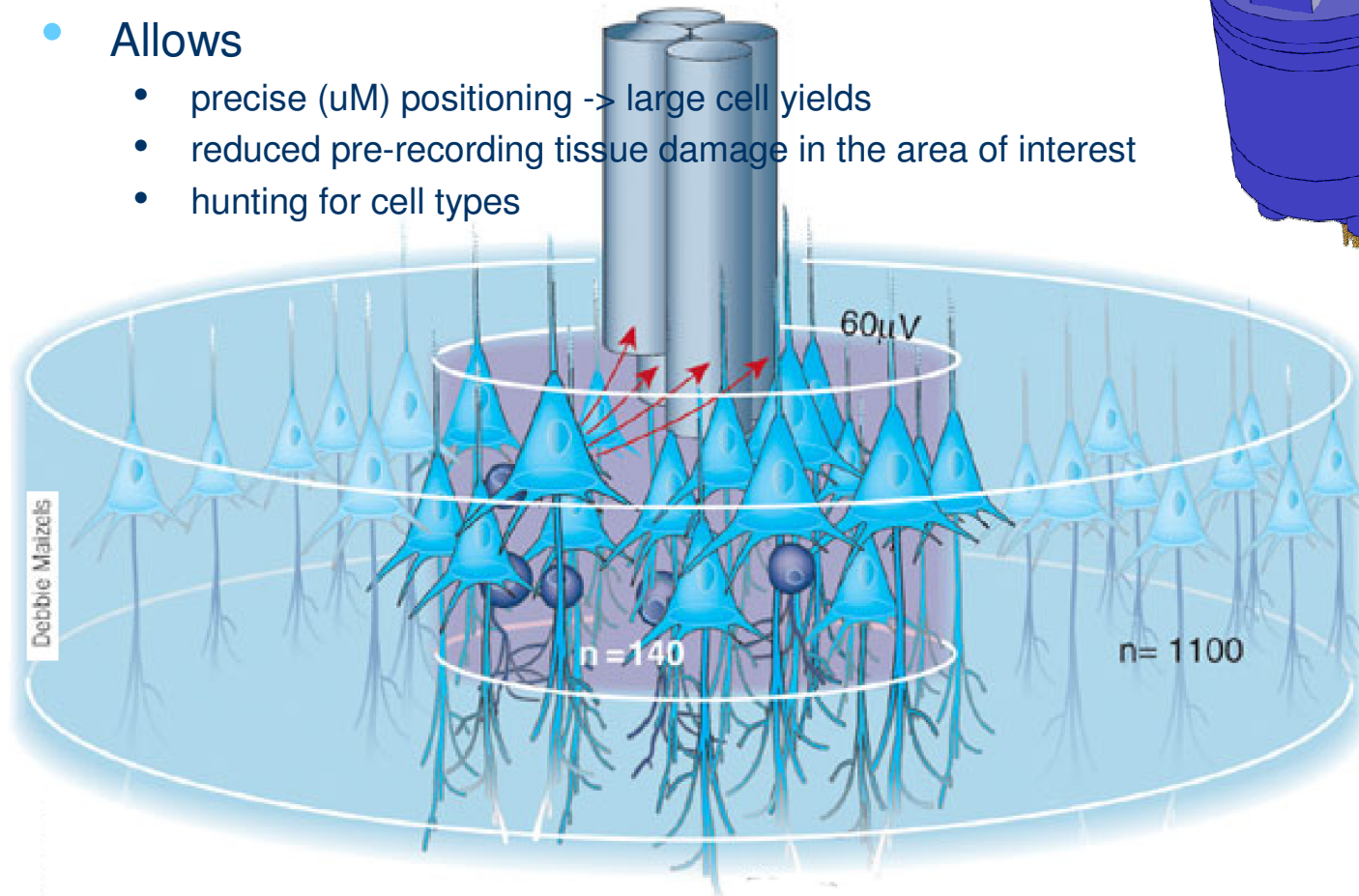
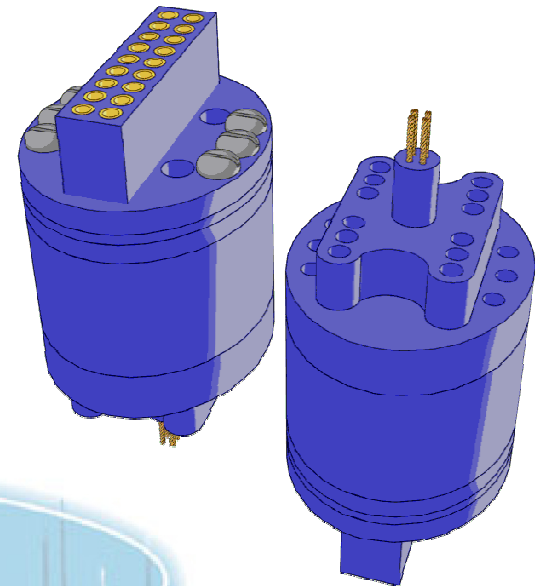

What can we measure?

- Combine different types of information
[Within and between regions]

- Behaviour
 - **Position**, heading, **speed**

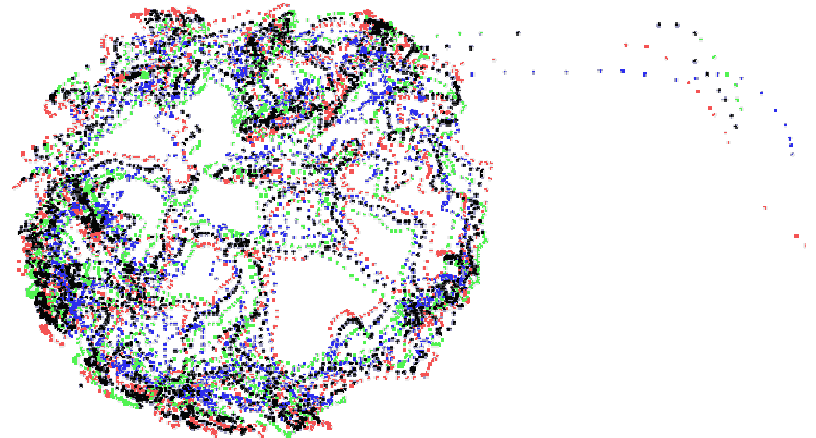

- EEG / Local field potentials (LFP)
 - **Theta**/gamma power spectrum
 - **Cycle detection**
 - Ripple/sharp-wave events

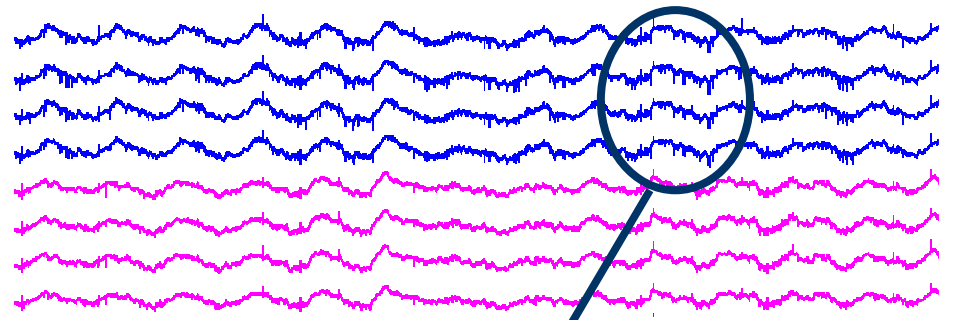

- Spiking
 - Action potential **waveforms**
 - **Activity levels** (firing rates)
 - **Temporal properties** (e.g. bursting)
 - **Behavioural correlates** (e.g. place fields)
 - **Relationship to LFP**

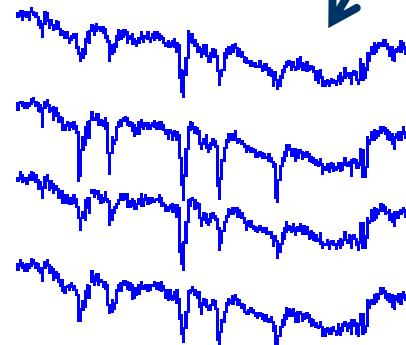

Benefits of a wireless system

Classical tethered system

- Additional training to accustom to presence of the cable
- Potential restriction of movement
- Limited to experiments using either
 - heavy cable (to turn a commutator)
 - -or-
 - simple open-top mazes but with constant monitoring to prevent cable-twisting

X 3Rs benefits

Wireless system

- Freedom of movement
- Reduced animal handling
- Reduced burden of weight for the animal
- Capacity to run more animals simultaneously, reducing duration of experiment
- Ability to use a wider variety of more naturalistic paradigms

✓ 3Rs benefits

Lilly

The challenge...

Overall objectives

To develop a prototype of a wireless 16-32 channel recording system that can acquire and transmit data for a minimum of 24h, that can be replaced or recharged with minimal discomfort for the animal and is small enough to be carried by a mouse without affecting its behaviour or welfare.

Key requirements

A wireless recording device that has the following specifications:

- Capability equivalent to recording 16 channels at 32kHz (ideally 32-64 channels).
- Any part of the system carried by the mouse must not weigh more than 3g
- Battery life of at least 24 hours to allow mice to learn multiple tasks within the T-maze, uninterrupted and without stressful insults.
- Event tracking integration, at least 8 independent event inputs to allow the behavioural data to be linked to the electrophysiological data.
- Scalable; must be ultimately possible to record from 8 animals in a single room.
- Interface with other commercially available electrodes, hardware and software
 - (e.g. Neuronexus, Neuralynx, etc).
- Flexibility in recording time and sampling rate.

The Lilly logo is written in a red, cursive script font.

Answers That Matter.